



**WACKER
NEUSON**
all it takes!

SW10 Skid Steer Loader

5 years /
5,000 hours
warranty

Versatility is the real driver of this machine.

The versatile SW10 Skid Steer Loader is an excellent addition to any hire or contractor fleet and is the perfect fit for landscaping projects, light site work, grading, auguring, general material handling and much more!

Key Features of the SW10.

- Skid steer loader with hydrostatic transmission realized with double axial pistons pump with variable displacement and four gear motors, sequently connected, on single wheels; (no chain drive).
- Hydraulic servo-controls to operate booms, bucket and travelling.
- Wide and comfortable driving place with canopy, lifted by springs, for rapid access and maintenance; FOPS, ROPS protection.
- The tilting safety bar side which safely disconnects all the servo controls when it is lifted, can be used also as an armrest to comfortably use the joysticks.
- Hydraulic power take off (PTO) to use various attachments.
- Quick hitches for predisposed buckets and various tools.

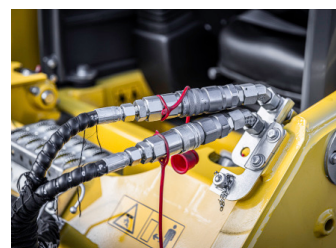

The construction equipment warranty terms and policy (Terms) covers all Wacker Neuson products sold by and in the Wacker Neuson Pty Ltd region of Australia and New Zealand. Product Registration is required to activate extended warranty period on eligible machines. Machines not registered within 30 days of purchase will have the Statutory 1 Year/1,000 hours warranty period.

SW10 Technical Information.

	Units	SW10
Rated Operating Capacity @35%	kg	280
Break-out force	daN	930
Operating weight	kg	1,850
Travel speed	km/h	0 - 10
Operating pressure – ground	bar	180
Lifting force (from ground)	daN	1,030
Pressure – auxiliary	l/min / bar	32
Engine/Motor		Kubota Water Cooled 4-Cylinder Diesel Engine V1505
Power	hp	24.8
Fuel tank capacity	litres	42
Hydraulic tank capacity	litres	30
Tyre size	mm	27 x 8.50 - 15
Cylinders		4
Drive system		Hydraulic motor with planetary reduction
Ground clearance	mm	185

SW10 Dimensions.

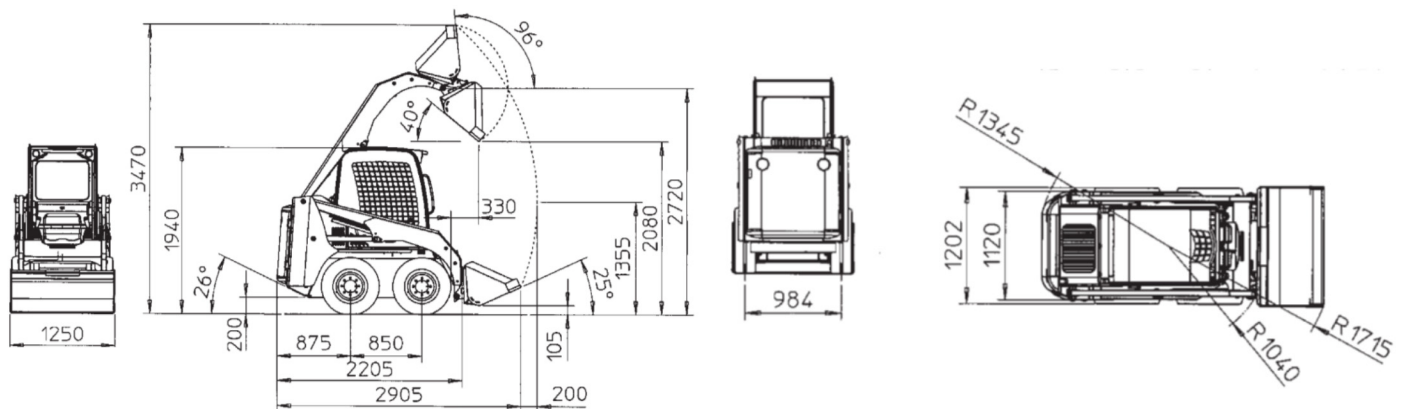

Dimensions in mm