

**MODEL:** **CG470**  
Air Suspension  
8 x 4

GVW: 31000kg  
GCW: 55000kg



<b>ENGINE:</b>	UD Trucks	<b>Engine</b> GE13TD
	Type	Six cylinder in line, 24 valve, OHC, 4 stroke direct injection, turbo charged diesel with intercooler
	Displacement	13,074cc
	Bore and stroke	136 x 150mm
	Maximum output ISO	460 PS (340 kW) at 1800rpm (nett)
	Maximum torque ISO	2,255 Nm (1665lb/ft) at 1200rpm (nett)
	On load max rpm	2000
	Compression ratio	17.5:1
	Total oil capacity	42 litres
	Lubrication system	Forced feed by geared pump with full flow and by-pass spin-on filter
	Air cleaner	Dry paper dual element type (15inch)
	Standard air intake	Snorkel type at rear of cab
	Emission standard	ADR80/02- Japan 05LT (Meets Euro 5 emission levels)
	Primary	Selective Catalytic Reduction (SCR)
Secondary	Electronic controlled selective cooled EGR	
AdBlue tank	33 litre stainless steel mounted of LHS chassis	

**UD TRUCKS MOTOR GE13TD ENGINE PERFORMANCE CURVE**

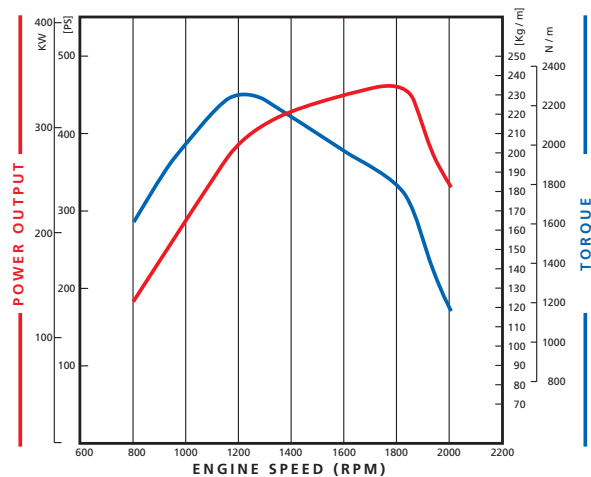

<b>Engine Cooling System</b>	
Radiator	Corrugated fin type
Water pump	Centrifugal
Header tank	Expansion type fitted
Temperature control	Wax pellet type thermostat
Lubricating oil	Oil cooler fitted
Fan	8 blade, mounted on viscous hub

<b>DRIVELINE, ELECTRICAL &amp; FUEL:</b>	<b>Clutch</b>	UD Trucks CLB10H
	Type	Dry twin plate. Air servo-assisted Hydraulically operated release system
	Clutch diameter	400mm
	<b>Front Axle</b>	UD Trucks FF85 Dropped Forged reverse Elliot "1" Beam Factory Rated at 8500Kg each
	<b>Rear Axle</b>	UD Trucks RM1AA
	Type	Fully floating pressed steel banjo housing
	Factory rated at	10,500kg each
	<b>Differential</b>	UD Trucks IPHM-3/SRHM-2
	Type	Single reduction hypoid
	Standard Ratio	4.111:1
Option	4.625:1	

<b>Gearbox</b>	Eaton Fuller RTLO-18918B. Eighteen forward speeds, four reverse. Constant mesh on each shift
Model	
Gearshift	Mechanical remote control
Gear Ratios	(Low) (High)
Low	14.402 12.287
1st	8.510 7.260
2nd	6.048 5.160
3rd	4.384 3.740
4th	3.201 2.731
5th	2.275 1.941
6th	1.617 1.379
7th	1.172 1.000
8th	0.855 0.730
Rev.L	15.057 12.845
Rev.H	4.025 3.434
<b>Electrical System</b>	24 volt negative earth
System	
Batteries	2 x 12 volt 120 Ah.
Alternator	60 amp with built-in IC regulator
<b>Fuel system</b>	400 litre alloy tank mounted on LHS chassis
Tank Capacity	
Fuel system	Ultra high pressure unit injector

# CG470 AIR SUSPENSION

CHASSIS	Chassis		Suspension	
	Type	Ladder channel section side rails	Front	Semi-elliptic taper leaf springs. 90 x 1550mm
Dimension	300 x 90 x 8mm	Spring constant	46.4 kg / mm per spring	
Material	Pressed carbon steel 55kg / mm <sup>2</sup> tensile steel	Rear	Hendrickson HAS460 air bag rear suspension with double acting telescopic shock absorbers	
		Spring constant	12.8 kg/mm +/- 15%	
		Steering & Wheels		
Service	Dual line, full air, wedge type, ABS with ASR. Oil mist separator and air dryer	Type	Integral power assisted recirculating ball steering box with additional power cylinder	
Drum dimensions	Dry paper dual element type (15inch)	Reduction ratio	22.42	
Front	410 x 180 mm	Steering wheel	460mm diameter moulded polyurethane grip	
Rear	410 x 220 mm	Steering column	Fore / aft tilt, telescopic and lockable	
Total lining	13,264 cm <sup>2</sup>	Road Wheels	Pressed steel disc 8.25 x 22.5, ISO 335mm PCD, 10 stud 165mm offset	
Parking brakes	Spring brakes acting on rear wheels.	Tyres	Bridgestone 11R22.5 tubeless radials	
Auxiliary brakes	UD Trucks EE decompression brake plus exhaust butterfly type brake	Option	Bridgestone 275/70 R 22.5	

CAB & INSTRUMENTS	Guages		Interior	
	Instrument gauges	Fuel, water temperature, dual air pressure, tachometer, speedometer with odometer and trip meter. Drivers information centre incorporating date/ time, trip information and service intervals. AdBlue level indicator	Drivers seat	Cloth trimmed high-back multi adjustable air suspended seat with automatic height control. 3 point ELR lap sash seatbelts
		Passengers seat	Cloth trimmed reclining high-back type fixed seat with lift up base 3 point ELR lap sash seatbelt	
		Warning Devices		
Warning lamps	Warning lamps Engine control warning, low air pressure, parking brake/spring brake, hazard, air filter element, low oil pressure, oil filter clog, oil pressure, battery charge, SCR trouble, AdBlue quality indicator	Sun visors	Driver and passenger side	
		Overhead tray	Document holder's on drivers and passenger side	
		Cup holder	Hot/cold holder in centre console	
		Floor covering	Vinyl	
		Bunk	Bed in rear of cab, cloth trimmed type.	
		Audible warning		
Devices include	Brake, low air pressure, coolant level and overheating, reversing, tilt lock, AdBlue low level	Control switches	Two stalk controls which incorporate Reversing lamp, roofing marker lamps 1. Turn signal, lighting 2. Wiper/washer/engine/exhaust brake, hazard warning, cruise control	
		Exterior		
Type	Steel Construction fully suspended forward control	Features	<ul style="list-style-type: none"> <li>• Door intrusion bars</li> <li>• Air conditioner/Heater demister - 4 mode operation with 4 speed fan</li> <li>• Engine idling control button</li> <li>• Electric windows</li> <li>• Central Locking</li> <li>• AM/FM radio with CD player</li> <li>• Cigar lighter</li> <li>• Electric horn</li> <li>• Foot rest</li> <li>• Spare tyre</li> <li>• Equipped tyre carrier</li> <li>• Tool kit</li> </ul>	
Cab suspension	Full air suspension with hydraulic shock absorbers	Lamps	<ul style="list-style-type: none"> <li>• Halogen head lamps</li> <li>• Hazard / Turn signal/ Clearance lamps</li> <li>• Stop / Tail lamps</li> <li>• Reversing Lamp</li> <li>• Roof marker lamps</li> <li>• License plate lamp</li> </ul>	
Tilting	Electrically driven with hydraulic assistance to 65 deg			
Windshield	Laminated tinted safety glass			
Windshield wiper	Three arms, dual speed with intermittent operation			
Side and rear windows	Tinted safety glass			
Cab front lid	Hinged for easy checking of maintenance (clutch fluid, coolant, engine oil)			
Mirrors	Heated and electrically operated main mirrors. Passenger side rear and downward spotter mirrors			

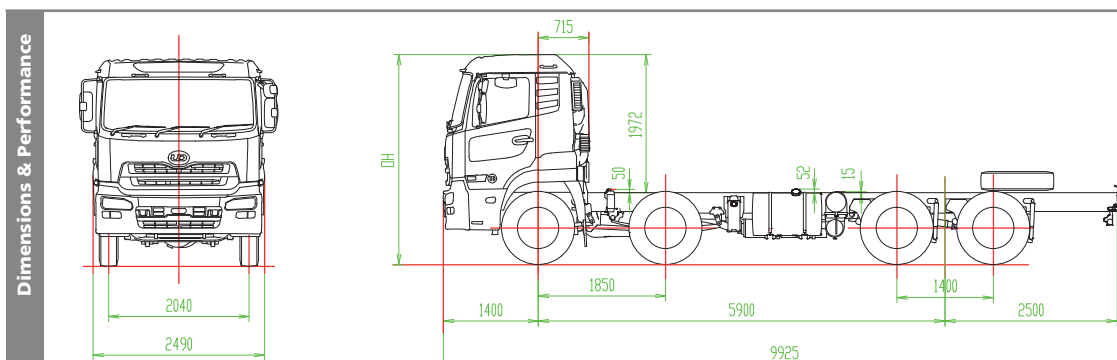

**Cab & Chassis Weights Kg**

CONDITION 1*			
Model	Front	Rear	Total
CG470 air	6200	2560	8760

CONDITION 2*			
Model	Front	Rear	Total
CG470 air	6360	2770	9030

\*With 20 litres of fuel, no spare wheel or tools

\* With 400 litres of fuel, spare wheel and tools



**UD TRUCKS**

This specification sheet applies to vehicles supplied by UD Truck Distributors (NZ) Ltd for the New Zealand market from January 2009. In accordance with UD Trucks Corporation policy of continuous improvement, the right is reserved to change specifications without notice.

UD Truck Distributors (NZ) Ltd, P O Box 76 326, Manukau City 2241.